

FG121



Afgegeven in overeenstemming met de Bouwproductenrichtlijn (CPD) 305/2011 / EU.
pgb-Europe nv verklaart hierbij dat de onderstaande producten voldoen aan de eisen van:

ETAG 015 (EAD 130186-00-0603) – driedimensionale spijkerplaten

1. *Unieke identificatiecode van het product:*
FG121
2. *Type- of serienummer of een ander element dat identificatie van het bouwproduct mogelijk maakt zoals vereist op grond van artikel 11(4)*
zie bijlage 1 van deze document
3. *Beoogd gebruik van het bouwproduct, in overeenstemming met de toepasbaar geharmoniseerde norm volgens technische specificatie voorzien door de fabrikant:*

Generiek type:	<i>Balkendrager uitwendige lippen</i>
Materiaal:	<i>Staalband S250GD</i>
Corrosie bescherming:	<i>Vuurverzinkt $\geq 275g/m^2$, voorverzinkt</i>
Serviceklasse:	<i>Serviceklasse I en II</i>
Vuur weerstand:	<i>Niet beoordeeld</i>
Reactie bij brand:	<i>Euroclass A1</i>
Beoogd gebruik:	<i>Houtverbinder voor hout op hout verbindingen en hout op beton verbindingen</i>

4. *Naam, geregistreerde handelsnaam of geregistreerd handelsmerk en contactadres van de fabrikant zoals vereist op grond van artikel 11 (5):*
pgb-Europe nv – Gontrode Heirweg 170 – 9090 Melle – Belgium
5. *Indien van toepassing, naam en contactadres van de gemachtigde vertegenwoordiger wie mandaat betrekking heeft op de taken gespecificeerd in artikel 12 (2):*
NIET VAN TOEPASSING
6. *Systeem of systemen voor de beoordeling en verificatie van de prestatieverklaring van het bouwproduct, zoals uiteengezet in bijlage V:*
System 2+
7. *Indien de prestatieverklaring betrekking heeft op een bouwproduct dat onder een geharmoniseerde norm*

standaard: ETAG 015 (EAD 130186-00-0603)
verricht door: Karlsruher Institut für Technologie (KIT)
onder systeem: 2+
en uitgegeven: 0769-CPD-6076

8. Indien de prestatieverklaring betrekking heeft op een bouwproduct waarvoor een Europese technische beoordeling is afgegeven:

NIET VAN TOEPASSING

9. Aangegeven prestaties:

Fastener types and sizes

NAIL diameter	Length Min – max	Nail type
4.0	25 - 100	Ringed shank nails according to EN 14592
<p>In the formulas in Annex B the capacities for threaded nails calculated from the formulas of Eurocode 5 are used assuming a thick steel plate when calculating the lateral nail load-carrying-capacity. The load bearing capacities of the joist hangers has been determined based on the use of connector nails 4,0 x L mm in accordance with the German national approval for the nails. The characteristic withdrawal capacity of the nails has to be determined by calculation in accordance with EN 1995-1-1: 2004, paragraph 8.3.2 (head pull-through is not relevant):</p> $F_{ax,Rk} = f_{1,k} \times d \times t_{pen}$ <p>Where:</p> <p>$f_{1,k}$ Characteristic value of the withdrawal parameter in N/mm² d Nail diameter in mm t_{pen} Penetration depth of the profiled shank in mm</p> <p>Based on tests by Versuchsanstalt für Stahl, Holz und Steine, University of Karlsruhe, the characteristic value of the withdrawal resistance for the threaded nails used can be calculated as:</p> $f_{1,k} = 50 \times 10^{-6} \times \rho_k^2$ <p>Where:</p> <p>ρ_k Characteristic density of the timber in kg/m³</p> <p>The shape of the nail directly under the head shall be in the form of a truncated cone with a diameter under the nail head which exceeds the hole diameter.</p>		

BOLTS diameter	Correspondence Hole diameter	Bolts type
10.0	Max. 2 mm. larger than the bolt diameter	See specification of the manufacturer

Characteristic capacities of the joist hanger connections with nails only

The downward and the upward directed forces are assumed to act in the middle of the joist. The lateral force is assumed to act at an distance $e_{j,90}$ above the centre of gravity of the nails in the joist.

Two nails patterns are specified. A full nailing pattern, where there are nails in all the holes and a partial nailing pattern, where the number of nails in the joist and the header are at least half the numbers specified for full nailing. The nails in the joist may be staggered. The nails in the header shall be put in the holes closest to the bend line.

For FG joist hangers the width of the joist shall be at least $l+4d$, where l is the length of the nails and d is the diameter of the nails in the joist, for full nailing and partial nailing without staggering the nails in the joist. For partial nailing with staggered nails in the joist the width shall be at least the penetration length of the nails.

B.1 Joist hangers types A and B fastened with nails

Force downward toward the bottom plate:

$$F_{Z,Rd} = \min \left\{ \begin{array}{l} (n_J + 2) \cdot F_{v,J,Rd} \\ \frac{1}{\sqrt{\left(\frac{1}{n_H \cdot F_{v,H,Rd}}\right)^2 + \left(\frac{1}{k_{H,1} \cdot F_{ax,H,Rd}}\right)^2}} \end{array} \right. \quad (B.1.1.1)$$

Force upward away from the bottom plate:

$$F_{Z,Rd} = \min \left\{ \begin{array}{l} n_J \cdot F_{v,J,Rd} \\ \frac{1}{\sqrt{\left(\frac{1}{n_H \cdot F_{v,H,Rd}}\right)^2 + \left(\frac{1}{k_{H,2} \cdot F_{ax,H,Rd}}\right)^2}} \end{array} \right. \quad (B.1.1.2)$$

Lateral force:

$$F_{Y,Rd} = \min \left\{ \begin{array}{l} \frac{n_J \cdot F_{v,J,Rd}}{\sqrt{\left(\frac{2 \cdot \sqrt{e_{j,0}^2 + e_{j,90}^2}}{b_J}\right)^2 + \left(\frac{F_{v,J,Rd}}{F_{ax,J,Rd}}\right)^2}} \\ \frac{F_{v,H,Rd}}{\sqrt{\left(\frac{1}{n_H} + \frac{e_H}{e_1}\right)^2 + \left(\frac{e_H}{e_2}\right)^2}} \end{array} \right. \quad (B.1.1.3)$$

- ¹ n_J total number of nails in both sides of the joist
- n_H total number of nails in the side of the header
- F_{v,Rd} Characteristic lateral load-carrying capacity of the fasteners in the joist or in the header indicated by the indices J or H
- F_{ax,Rd} Characteristic axial load-carrying capacity of the fasteners in the joist or in the header indicated by the indices J or H
- b_J width of the joist hanger, see figure B1.
- e_{J,90} distance of the lateral force above the centre of gravity of the nails in the joist, see figure B1.
- e_{J,0} distance from the nails in the joist to the surface of the header, see figure B1.
- e_H distance of the lateral force above the centre of gravity of the nails in the header.
- e₁ joist hanger dimension, see Annex C
- e₂ joist hanger dimension, see Annex C

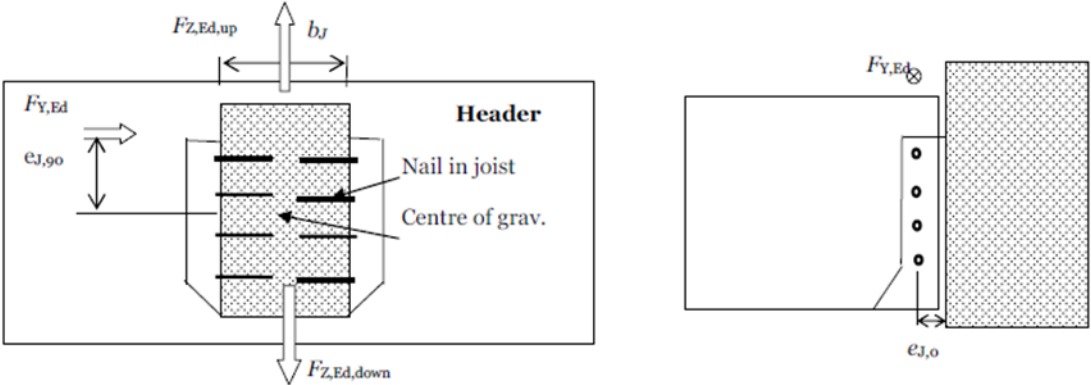

Figure B1: Definition of $e_{1,90}$ and $e_{1,0}$

B.1.2 Combined forces

In case of combined forces shall the following inequality be fulfilled:

$$\left(\frac{F_{Y,Ed}}{F_{Y,Rd}}\right)^2 + \left(\frac{F_{Z,Ed}}{F_{Z,Rd}}\right)^2 \leq 1 \tag{B.1.2.1}$$

$k_{H,1}$ form factor, see Annex C
 $k_{H,2}$ form factor, see Annex C

B.2 Characteristic capacities of the joist hanger type A connections with bolts

For joist hangers type A connected to a wall of concrete, lightweight concrete or to a steel member the assumptions for the calculation of the load-carrying capacity of the connection are:

- The transfer of force from the joist to the joist hanger is as for a wood-wood connection, see clause B.1;
- The bolts shall always be positioned symmetrically about the vertical axis of the joist hanger;
- Washers according to EN ISO 7094 shall be installed at least under the upper 2 bolt heads or nuts.

Description of the static model

For a downward directed force toward the bottom plate the static behavior is basically the same as for a wood-wood connection with nails.

The nails in the joist are subjected to a lateral force, which is equally distributed over all nails in the joist.

Since the concrete and steel have a larger compressive strength than timber subjected perpendicular to the grain the rotation point may be assumed positioned at the top of the bottom plate.

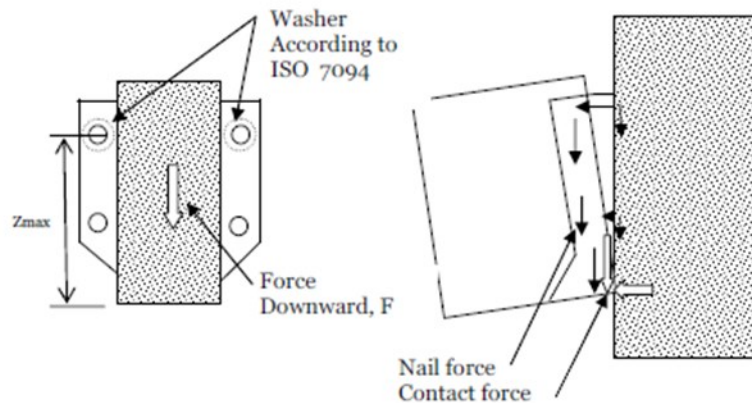

Figure B2 Left: Cross section in joist. Right: The joist will deflect and rotate, at the bottom a contact force will occur at the bottom plate, and the withdrawal forces in the bolts in the wall will vary linearly as assumed for nailed connections in the header.

The forces in the bolts will be partly lateral forces, partly withdrawal forces. The lateral forces are distributed evenly over all bolts. The withdrawal forces are on the safe side assumed to be taken by the 2 upper bolts with washers. The maximum withdrawal force in a upper bolt can be calculated from

$$F_{\text{ax,bolt}} = \frac{F \cdot e_{j,0}}{2 \cdot z_{\text{max}}} \quad (\text{B.2.1})$$

Where

F downward directed force toward the bottom plate;

$e_{j,0}$ eccentricity = distance from the nail column in the joist to the surface of the header;

z_{max} max distance from upper bolt to the bottom plate (rotation point).

The upper 2 bolts are critical. They are subjected to a lateral force and a withdrawal force. The lateral force is determined assuming an even distribution of the downward force F.

$$F_{\text{lat,bolt}} = F / n_{\text{bolt}} \quad (\text{B.2.2})$$

PRESTATIEVERKLARING

DoP FG121001A-NL page 6 / 8

Form factors $k_{H,1}$ and $k_{H,2}$ and dimensions e_1 , e_2 and $e_{J,0}$

B [mm]	H [mm]	n_H	n_J	$k_{H,1}$	$k_{H,2}$	e_1 [mm]	e_2 [mm]	$e_{J,0}$ [mm]	n_H	n_J	$k_{H,1}$	$k_{H,2}$	e_1 [mm]	e_2 [mm]	$e_{J,0}$ [mm]
Full nailing									Partial nailing						
51	90	10	6	11,1	2,82	1253	421	32	6	4	6,85	1,88	525	273	32
60	85	10	6	9,90	3,02	1474	461	32	6	4	6,14	2,02	635	295	32
64	83	10	6	9,38	3,13	1579	478	32	6	4	5,83	2,08	688	306	32
25	118	14	8	23,0	5,72	793	511	32	8	4	13,3	3,54	307	361	32
32	114	14	8	21,7	5,92	911	547	32	8	4	12,6	3,65	358	370	32
38	111	14	8	20,6	6,12	1022	578	32	8	4	12,0	3,76	406	381	32
40	110	14	8	20,2	6,18	1060	589	32	8	4	11,8	3,80	424	385	32
50	105	14	8	18,3	6,54	1268	645	32	8	4	10,8	4,02	518	409	32
60	100	14	8	16,6	6,94	1499	703	32	8	4	9,77	4,27	626	437	32
63	99	14	8	16,0	7,07	1573	720	32	8	4	9,47	4,35	661	446	32
70	95	14	8	14,8	7,39	1753	762	32	8	4	8,80	4,55	748	467	32
60	120	18	10	24,9	12,5	1581	988	32	10	6	14,2	7,35	662	616	32
64	118	18	10	24,0	12,8	1677	1017	32	10	6	13,8	7,50	706	628	32
40	140	18	10	34,1	10,5	1027	856	32	10	6	19,3	6,15	420	572	32
51	135	18	10	31,5	10,9	1225	927	32	10	6	17,8	6,44	507	593	32
60	130	18	10	29,4	11,4	1406	988	32	10	6	16,7	6,70	589	616	32
63	129	18	10	28,7	11,5	1469	1010	32	10	6	16,3	6,79	618	625	32
64	128	18	10	28,5	11,6	1491	1017	32	10	6	16,2	6,82	628	628	32
70	125	18	10	27,1	11,9	1625	1060	32	10	6	15,4	7,01	690	647	32
75	123	18	10	26,0	12,2	1742	1097	32	10	6	14,8	7,18	745	663	32
80	120	18	10	24,9	12,5	1864	1134	32	10	6	14,2	7,35	802	681	32
80	140	20	10	34,6	14,6	2208	1343	32	10	6	19,3	6,15	802	681	32
60	160	22	12	45,8	16,9	1703	1330	32	12	6	25,4	9,68	724	842	32
63	159	22	12	45,0	17,1	1773	1354	32	12	6	25,0	9,79	755	849	32
70	155	22	12	43,0	17,6	1945	1410	32	12	6	23,9	10,0	833	868	32
71	155	22	12	42,7	17,6	1971	1418	32	12	6	23,8	10,1	845	871	32
75	153	22	12	41,6	17,9	2075	1451	32	12	6	23,2	10,2	892	883	32
76	152	22	12	41,3	18,0	2101	1459	32	12	6	23,0	10,3	904	887	32
80	150	22	12	40,2	18,2	2209	1493	32	12	6	22,4	10,4	954	900	32
90	145	22	12	37,5	18,9	2496	1579	32	12	6	21,0	10,8	1087	937	32
100	140	22	12	34,8	19,7	2804	1669	32	12	6	19,5	11,3	1233	978	32
100	160	24	14	46,0	23,3	2618	1870	32	14	8	25,6	16,0	1299	1238	32
40	200	26	14	72,7	22,3	1333	1604	32	14	8	39,6	12,5	579	1141	32
60	190	26	14	65,9	23,6	1714	1741	32	14	8	36,0	13,2	743	1123	32
63	189	26	14	64,9	23,8	1779	1765	32	14	8	35,4	13,3	771	1126	32
71	185	26	14	62,2	24,4	1958	1832	32	14	8	34,0	13,7	851	1141	32
75	183	26	14	60,9	24,7	2053	1866	32	14	8	33,3	13,8	894	1151	32
80	180	26	14	59,2	25,1	2176	1911	32	14	8	32,4	14,0	950	1165	32
100	170	26	14	52,7	26,7	2718	2103	32	14	8	29,0	15,0	1199	1238	32
120	160	26	14	46,5	28,6	3339	2309	32	14	8	25,6	16,0	1492	1329	32
120	180	28	16	59,6	31,6	3751	2594	32	14	8	32,4	14,0	1492	1329	32
60	220	30	16	89,5	31,4	2042	2233	32	16	8	48,3	17,3	903	1469	32
75	213	30	16	83,7	32,6	2405	2355	32	16	8	45,2	18,0	1063	1473	32

Form factors $k_{H,1}$ and $k_{H,2}$ and dimensions e_1 , e_2 and $e_{T,0}$

B [mm]	H [mm]	n_H	n_J	$k_{H,1}$	$k_{H,2}$	e_1 [mm]	e_2 [mm]	$e_{T,0}$ [mm]	n_H	n_J	$k_{H,1}$	$k_{H,2}$	e_1 [mm]	e_2 [mm]	$e_{T,0}$ [mm]
Full nailing									Partial nailing						
80	210	30	16	81,8	33,0	2537	2400	32	16	8	44,2	18,2	1122	1482	32
100	200	30	16	74,2	34,9	3118	2599	32	16	8	40,2	19,2	1387	1541	32
120	190	30	16	66,9	36,9	3785	2819	32	16	8	36,3	20,3	1698	1628	32
140	180	30	16	59,8	39,2	4538	3054	32	16	8	32,6	21,6	2055	1733	32

10. De prestaties van het product geïdentificeerd in punt 1 en 2 is in overeenstemming met de aangegeven prestaties in punt 9. Deze prestatieverklaring wordt opgesteld onder de exclusieve verantwoordelijkheid van pgb-Europe nv.

Plaats en datum van uitgave	Ondertekend voor en namens de fabrikant door	
Melle, 09/05/2014	nv pgb-Europe sa Gontrode Heirweg 170 9090 MELLE BE 0425 888 396	Johannes Heye, product manager 

Bijlage 1 : Productoverzicht

Steel	www.pgb-europe.com	€
JOIST HANGER type A Material : Steel Surface : sendzimir zinc plated	ZWARE BALKENDRAGER uitwendige lippen Materiaal : Staal Oppervlak : sendzimir verzinkt SABOT alles extérieures Matière : Acier Surface : zingué sendzimir BALKENSCHUH nach aussen abgewinkelt Material : Stahl Oberfläche : sendzimir verzinkt	FG121 Joist hanger 

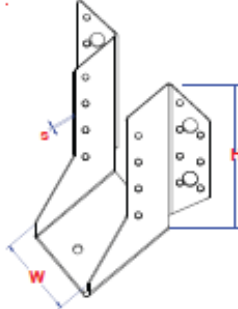

Price / 1		Dimensions in mm				Packing Unit	
Prijs - Prix - Preis / 1		Afmetingen in mm - Dimensions en mm - Abmessungen in mm				Verpakking / Emballage / Packung	
Art.Nr	EAN Nr.	s	type	W	H		
FG121,025117Z	5410439336970	2,00	260	25,00	117	*****	10
FG121,032114Z	5410439337007	2,00	260	32,00	114	*****	10
FG121,040110Z	5410439332781	2,00	260	40,00	110	*****	10
FG121,040148Z	5410439359924	2,00	380		148	*****	10
FG121,046102Z	5410439385305	2,00	250	46,00	102	*****	10
FG121,046144Z	5410439629072	2,00	335		144	*****	10
FG121,050105Z	5410439332804	2,00	260	50,00	105	*****	10
FG121,050143Z	5410439359887	2,00	380		143	*****	10
FG121,059100Z	5410439332828	2,00	260	59,00	100	*****	10
FG121,059138Z	5410439359900	2,00	320		138	*****	10
FG121,059160Z	5410439332811	2,00	380		160	*****	10
FG121,059190Z	5410439337038	2,00	440		190	*****	10
FG121,063098Z	5410439332835	2,00	260	63,00	98	*****	10
FG121,063128Z	5410439332842	2,00	320		128	*****	10
FG121,063158Z	5410439332859	2,00	380		158	*****	10
FG121,063188Z	5410439337069	2,00	440		188	*****	10
FG121,071095Z	5410439337090	2,00	260	71,00	95	*****	10
FG121,071125Z	5410439337120	2,00	320		125	*****	10
FG121,071154Z	5410439337151	2,00	380		154	*****	10
FG121,071184Z	5410439337182	2,00	440		184	*****	10
FG121,075122Z	5410439332866	2,00	320	75,00	122	*****	10
FG121,075152Z	5410439332873	2,00	380		152	*****	10
FG121,075182Z	5410439332880	2,00	440		182	*****	10
FG121,075212Z	5410439332897	2,00	500		212	*****	10
FG121,100140Z	5410439337212	2,00	380	100,0	140	*****	10
FG121,120160Z	5410439337243	2,00	440	120,0	160	*****	10