



DÉCLARATION DES PERFORMANCES



DoP: 0050

pour Ancrage pour fixation lourde fischer TA M, TA M S, TA M T (Cheville métallique pour utilisation dans le béton (charges lourdes)) – FR

1. Code d'identification unique du produit type: **DoP: 0050**
2. Usage(s) prévu(s): **Cheville de fixation dans du béton non fissuré, voir annexe, en particulier annexes B 1 - B 3**
3. Fabricant: **fischerwerke GmbH & Co. KG, Klaus-Fischer-Straße 1, 72178 Waldachtal, Allemagne**
4. Mandataire: --
5. Système(s) d'évaluation et de vérification de la constance des performances: **1**
6. Document d'évaluation européen: **EAD 330232-00-0601**

Évaluation technique européenne: **ETA-04/0003; 2018-06-12**

Organisme d'évaluation technique: **DIBt**

Organisme(s) notifié(s): **1343 – MPA Darmstadt**

7. Performance(s) déclarée(s):

Résistance mécanique et stabilité (BWR 1)

- **résistance caractéristique à la traction (pour l'action statique et quasi-statique):**
Voir annexe, en particulier annexe C 1
- **résistance caractéristique au cisaillement (pour l'action statique et quasi-statique):**
Voir annexe, en particulier annexe C 2
- **Déplacements (pour l'action statique et quasi-statique):** Voir annexe, en particulier annexe C 2
- **Résistance caractéristique et déplacements pour catégories de performance sismique C1 et C2:** NPD

Protection contre le feu (BWR 2)

- **Réaction au feu:** La cheville remplit les exigences de la classe A 1
- **Résistance au feu:** NPD

8. Documentation technique appropriée et/ou documentation technique spécifique: ---

Les performances du produit identifié ci-dessus sont conformes aux performances déclarées. Conformément au règlement (UE) no 305/2011, la présente déclaration des performances est établie sous la seule responsabilité du fabricant mentionné ci-dessus.

Signé pour le fabricant et en son nom par:

Andreas Bucher, Dipl.-Ing.

Wolfgang Hengesbach, Dipl.-Ing., Dipl.-Wirtsch.-Ing.

Tumlingen, 2018-06-19

- Cette déclaration des performances a été émise en différentes langues. En cas de divergences d'interprétation, la version anglaise prévaut toujours.
- L'annexe contient des informations volontaires et complémentaires en langue anglaise dépassant les exigences légales (spécifiées en langage neutre).

Specific Part

1 Technical description of the product

The Fischer Heavy-duty anchor TA M, TA M S and TA M T in the range of M6, M8, M10 and M12 is an anchor made of galvanised steel which is placed into a drilled hole and anchored by torque-controlled expansion with the hexagon head bolt.

The product description is given in Annex A.

2 Specification of the intended use in accordance with the applicable European Assessment Document

The performances given in Section 3 are only valid if the concrete screw is used in compliance with the specifications and conditions given in Annex B.

The verifications and assessment methods on which this European Technical Assessment is based lead the assumption of working life of the concrete screw of at least 50 years. The indications given on the working life cannot be interpreted as a guarantee given by the producer, but are to be regarded only as a means for choosing the right products in relation to the expected economically reasonable working life of the works.

3 Performance of the product and references to the methods used for its assessment

3.1 Mechanical resistance and stability (BWR 1)

Essential characteristic	Performance
Characteristic resistance to tension load (static and quasi-static loading)	see Annex C 1
Characteristic resistance to shear load (static and quasi-static loading)	see Annex C 2
Displacements (static and quasi-static loading)	see Annex C 2
Characteristic resistance and displacements for seismic performance categories C1 and C2	No performance assessed

3.2 Safety in case of fire (BWR 2)

Essential characteristic	Performance
Reaction to fire	Class A1
Resistance to fire	No performance assessed

4 Assessment and verification of constancy of performance (AVCP) system applied, with reference to its legal base

In accordance with European Assessment Documents EAD No. 330232-00-0601 the applicable European legal act is: [96/582/EC].

The system to be applied is: 1

Pre-positioned installation:

TA M

The hexagon head screw and the washer according to table A4.1 and A4.2 must be provided by the user

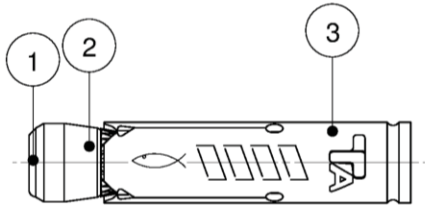

TA M S

The hexagon head screw is provided by the manufacturer (fischer) together with the anchor

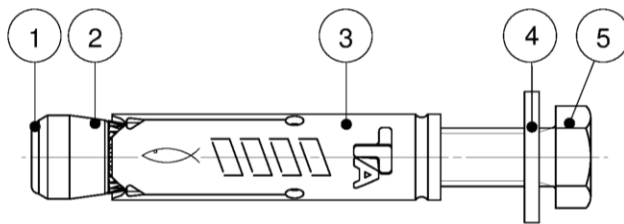

In-place installation:

TA M T

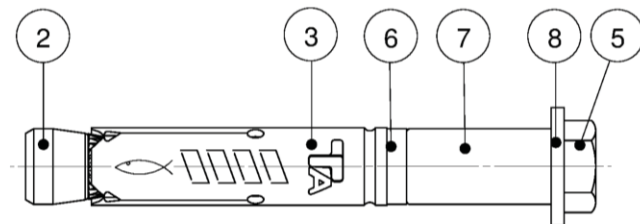

- | | |
|--------------------------|----------------------|
| 1 Plastic cap (optional) | 5 Hexagon head screw |
| 2 Cone-nut | 6 Distance ring |
| 3 Expansion sleeve | 7 Spacing sleeve |
| 4 Washer (TA M / TA M S) | 8 Washer (TA M T) |

(Fig. not to scale)

fischer Heavy-duty anchor TA M, TA M S, TA M T

Product description
Anchor types

Annex A 1

TAM / TAM S

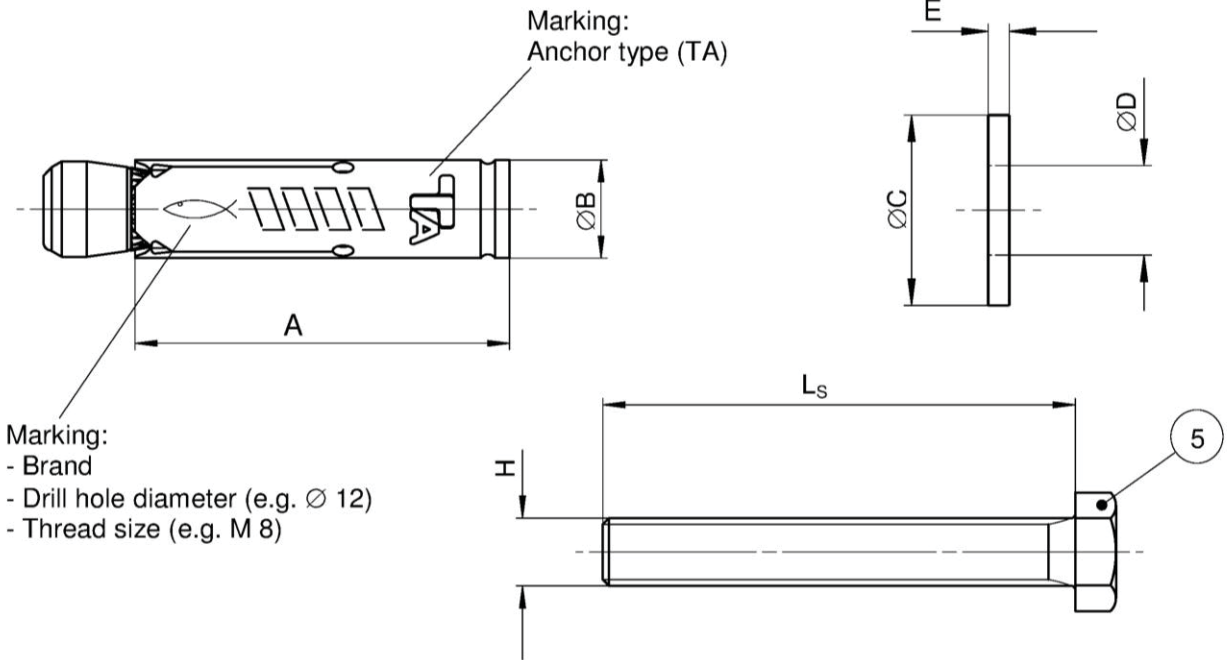

TAM T

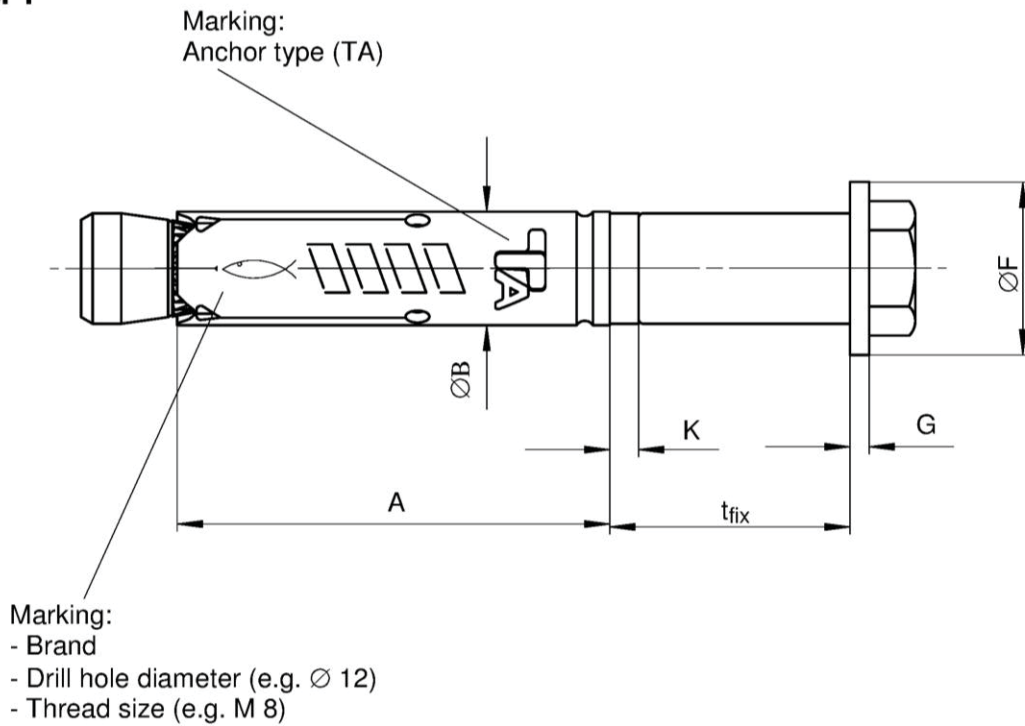

(Fig. not to scale)

fischer Heavy-duty anchor TAM, TAM S, TAM T

Product description
Anchor components

Annex A 2

Table A3.1: Anchor dimensions [mm]

Part	Designation	Type of anchor		M6	M8	M10	M12
3	Expansion sleeve	TA M / TA M S / TA M T	A	40,0	45,0	55,0	70,0
			∅ B	9,6	11,8	14,5	17,5
4	Washer ¹⁾	TA M S	∅ C ≥	11,0	15,0	19,0	23,0
			E ≥	1,4	1,4	1,8	2,3
8	Washer	TA M T	∅ F ≥	17,0	21,0	25,0	30,0
			G ≥	1,4	1,8	2,3	2,7
5	Hexagon head screw ²⁾	TA M S / TA M T	L _s ≥	t _{fix} + 50	t _{fix} + 55	t _{fix} + 70	t _{fix} + 85
			H	M6	M8	M10	M12
6	Distance ring	TA M T	K =	3,0	3,0	3,0	3,0

¹⁾ For specification - summary of washer for TA M see table A4.2

²⁾ For specification - summary of hexagon head screw for TA M see table A4.1

Table A3.2: Materials

Part	Designation	Type of anchor	Materials	Treatment
1	Plastic cap ¹⁾	TA M / TA M S	Polyamide	-
2	Cone-nut	TA M / TA M S / TA M T	Steel, EN 10277:2008	Zinc plated according to EN ISO 4042:2017, min 5 µm, additional functional coating
3	Expansion sleeve	TA M / TA M S / TA M T	Cold-rolled steel EN 10139:2016	Zinc plated according to EN ISO 4042:2017, min 5 µm
4	Washer ²⁾	TA M S	Steel, min 140 HV	
8	Washer	TA M T		
5	Hexagon head screw ³⁾	TA M S / TA M T	Steel, property class 8.8	
6	Distance ring	TA M T	Polyethylen	-
7	Distance sleeve	TA M T	Cold-rolled steel EN 10139:2016/ Steel EN 10 277:2008	Zinc plated according to EN ISO 4042:2017, min 5 µm

¹⁾ Optional

²⁾ For specification - summary of washer for TA M see table A4.2

³⁾ For specification - summary of hexagon head screw for TA M see table A4.1

fischer Heavy-duty anchor TA M, TA M S, TA M T

Product description
Anchor dimensions
Materials

Annex A 3

Table A4.1: Selection criteria for the hexagon head screw (TA M)

Description			TA M6	TA M8	TA M10	TA M12
Length of hexagon head screw	L_s	[mm]	$\geq t_{fix} + 50$	$\geq t_{fix} + 55$	$\geq t_{fix} + 70$	$\geq t_{fix} + 85$
Thread size	H	[-]	M6	M8	M10	M12
Standardisation			ISO 4014:2017 / ISO 4017:2014 or DIN 931:1987 / DIN 933:1987			
Material			Steel, property class 8.8			
Treatment			Zinc plated according to EN ISO 4042:2017, min 5 μ m			

Table A4.2: Selection criteria for the washer (TA M)

Description			TA M6	TA M8	TA M10	TA M12
Hole diameter	D	min	6,0	8,0	10,0	12,0
		max	6,6	8,6	10,8	13,3
External diameter	C	[mm]	$\geq 11,0$	$\geq 15,0$	$\geq 19,0$	$\geq 23,0$
Thickness	E	min	1,4	1,4	1,8	2,3
		max	3,0	3,0	4,0	5,0
Material			Steel, hardness class min 140 HV			
Treatment			Zinc plated according to EN ISO 4042:2017, min 5 μ m			

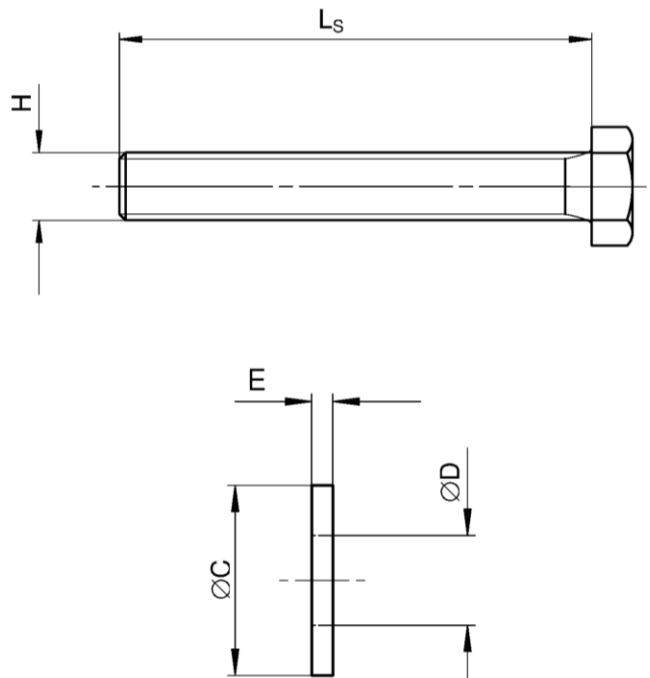

(Fig. not to scale)

fischer Heavy-duty anchor TA M, TA M S, TA M T

Product description
Dimensions
Materials

Annex A 4

Specifications of intended use

fischer Heavy-duty anchor	TA M6	TA M8	TA M10	TA M12
Steel, zinc plated			✓	
Static and quasi-static loads			✓	
Uncracked concrete			✓	

Base materials:

- Normal weight concrete according to EN 206-1:2000
- Strength classes C20/25 to C50/60 according to EN 206-1:2000

Use conditions (Environmental conditions):

- Structures subject to dry internal conditions

Design:

- Anchorages have to be designed under the responsibility of an engineer experienced in anchorages and concrete work
- Verifiable calculation notes and drawings have to be prepared taking account of the loads to be anchored. The position of the anchor is indicated on the design drawings (e.g. position of the anchor relative to reinforcement or to supports, etc.)
- Design of fastenings according to FprEN 1992-4: 2016 and EOTA Technical Report TR 055

Installation:

- Anchor installation carried out by appropriately qualified personnel and under the supervision of the person responsible for technical matters of the site
- Hammer or hollow drilling according to Annex B3
- Drill hole created perpendicular $\pm 5^\circ$ to concrete surface, positioning without damaging the reinforcement
- In case of aborted hole: new drilling at a minimum distance twice the depth of the aborted drill hole or smaller distance if the aborted drill hole is filled with high strength mortar and if under shear or oblique tension load it is not in the direction of load application

fischer Heavy-duty anchor TA M, TA M S, TA M T

Intended use
Specifications

Annex B 1

Table B2.1: Installation parameters for TA M / TA M S / TA M T

Anchor size		TA M6	TA M8	TA M10	TA M12
Nominal drill hole diameter	d_0	10	12	15	18
Maximum drill bit diameter	$d_{cut} \leq$	10,45	12,50	15,50	18,50
Length of hexagon head screw	$L_s \geq$	$t_{fix} + 50$	$t_{fix} + 55$	$t_{fix} + 70$	$t_{fix} + 85$
Depth of drill hole (TA M / TA M S)	$h_1 \geq$	$L_s - t_{fix} + 15$		$L_s - t_{fix} + 20$	
Depth of drill hole (TA M T)	$h_1 \geq$	$L_s + 10$			
Diameter of clearance hole in the fixture (TA M / TA M S)	$d_f \leq$	7	9	12	14
Diameter of clearance hole in the fixture (TA M T)	$d_f \leq$	12	14	18	20
Thickness of fixture	$t_{fix, min}$	1			
	$t_{fix, max}$	150	200	250	300
Required torque moment	T_{inst} [Nm]	10	20	40	75

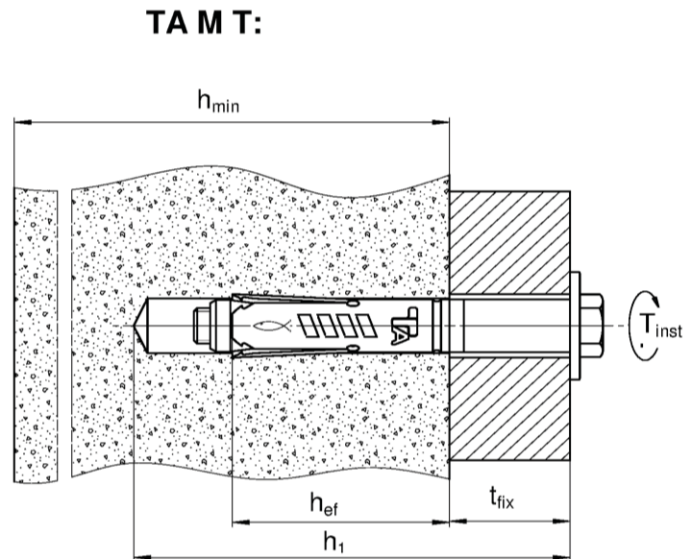
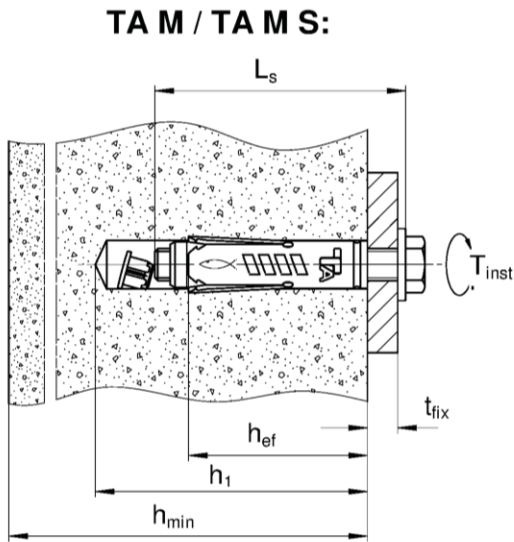

L_s = Length of hexagon head screw
 h_{ef} = Effective embedment depth
 t_{fix} = Thickness of the fixture

h_{min} = Minimum thickness of concrete member
 h_1 = Depth of drill hole to deepest point
 T_{inst} = Required setting torque

Table B2.2: Minimum thickness of concrete member, minimum spacing and minimum edge distances

Anchor size		TA M6	TA M8	TA M10	TA M12
Minimum thickness of concrete member	h_{min}	100	100	110	140
Minimum spacing	s_{min} [mm]	80	90	110	160
Minimum edge distance	c_{min}	50	60	70	120

(Fig. not to scale)

fischer Heavy-duty anchor TA M, TA M S, TA M T

Intended Use
 Installation instructions
 Minimum thickness of concrete member, minimum spacing and minimum edge distance

Annex B 2

Installation instruction

Pre-positioned installation TA M / TA M S

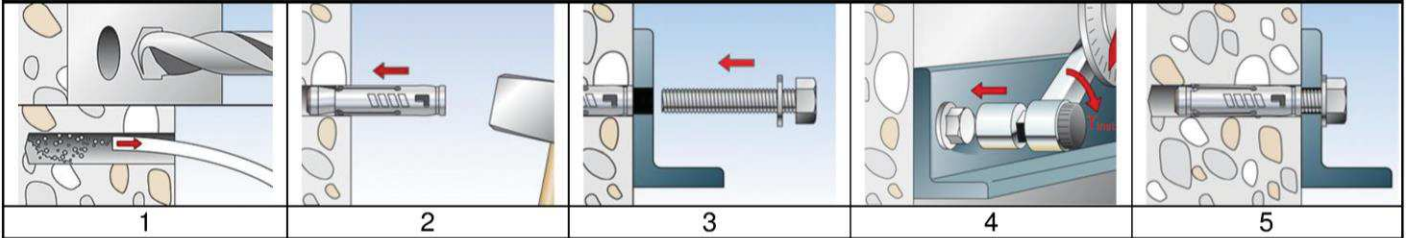

No.	Description	
1	Create drill hole with hammer drill, clean bore hole	Create drill hole with hollow drill and vacuum cleaner
2	Set the fastener	
3	Attach the fixture and turn the screw in	
4	Apply required torque moment T_{inst}	
5	Installed fastener	

Push-through installation TA M T

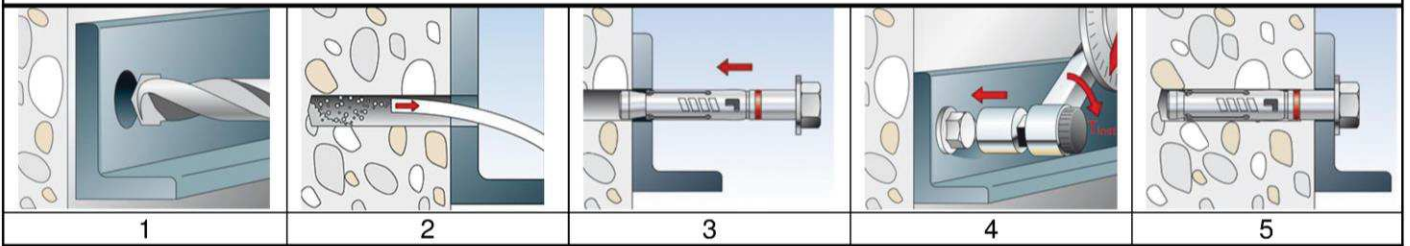

No.	Description	
1	Create drill hole with hammer drill	Create drill hole with hollow drill and vacuum cleaner
2	Clean bore hole	-
3	Set the fastener	
4	Apply required torque moment T_{inst}	
5	Installed fastener	

Types of drills

Hammer drill



Hollow drill



fischer Heavy-duty anchor TA M, TA M S, TA M T

Intended use
Installation instruction

Annex B 3

Table C 1.1: Characteristic <i>tension</i> resistance under static and quasi-static loads							
Anchor size		TA M6	TA M8	TA M10	TA M12		
Steel failure							
Characteristic resistance property class 8.8	$N_{Rk,s}$	[kN]	16,1	29,3	46,4	67,4	
Partial factor	γ_{Ms} ¹⁾	[-]	1,5				
Pull-out failure							
Characteristic resistance in uncracked concrete	$N_{Rk,p}$	[kN]	C20/25	7,5	12	20	25
Increasing factors for $N_{Rk,p}$ for uncracked concrete	ψ_c		C25/30	1,12			
			C30/37	1,22			
			C35/45	1,32			
			C40/50	1,41			
			C45/55	1,50			
			C50/60	1,58			
Installation factor	γ_{inst}	[-]	1,0				
Concrete cone failure and splitting failure							
Effective embedment depth	h_{ef}	[mm]	40	45	55	70	
Factor k_1	$k_{ucr,N}$	[-]	11,0 ²⁾				
Spacing (concrete cone failure)	$s_{cr,N}$	[mm]	120	135	220	210	
Edge distance (concrete cone failure)	$c_{cr,N}$		60	68	110	105	
Spacing (splitting)	$s_{cr,sp}$		120	180	330	420	
Edge distance (splitting)	$c_{cr,sp}$		60	90	165	210	
¹⁾ In absence of other national regulations ²⁾ Based on concrete strength as cylinder strength							
fischer Heavy-duty anchor TA M, TA M S, TA M T					Annex C 1		
Performances Characteristic tension resistance under static and quasi-static loads							

Table C2.1: Characteristic values of shear resistance under static and quasi-static loads					
Anchor size		TA M6	TA M8	TA M10	TA M12
Shear load without lever arm					
Characteristic resistance property class 8.8	$V_{Rk,s}^0$ [kN]	5,8	11,7	19,2	29,8
Partial factor	$\gamma_{Ms}^{1)}$ [-]	1,25			
Ductility factor	k_7 [-]	1,0			
Shear load with lever arm					
Characteristic bending moment property class 8.8	$M_{Rk,s}^0$ [Nm]	12	30	60	105
Partial factor	$\gamma_{Ms}^{1)}$ [-]	1,25			
Concrete pryout failure					
Ductility factor	k_7 [-]	1,0			
Factor	k_8 [-]	1,1	1,8	1,8	2,0
Concrete edge failure					
Effective length of the fastener	l_f [mm]	40	45	55	70
Outside diameter of fastener	d_{nom} [mm]	10	12	15	18
¹⁾ In absence of other national regulations					
Table C2.2: Displacements under static and quasi static tension loads					
Anchor size		TA M6	TA M8	TA M10	TA M12
Tension load in uncracked concrete	[kN]	3,0	4,8	7,9	9,9
Displacements	$\frac{\delta_{N0}}{\delta_{N\infty}}$ [mm]	0,7	0,7	1,2	1,2
		1,0	1,0	1,8	1,8
Table C2.3: Displacements under static and quasi static shear loads					
Anchor size		TA M6	TA M8	TA M10	TA M12
Shear load in uncracked concrete	[kN]	3,3	6,7	11,0	17,0
Displacements	$\frac{\delta_{V0}}{\delta_{V\infty}}$ [mm]	2,1	1,9	3,1	3,3
		3,1	2,8	4,6	4,9
fischer Heavy-duty anchor TA M, TA M S, TA M T					Annex C 2
Performances Characteristic shear resistance under static and quasi-static loads Displacements under tension and shear loads					